

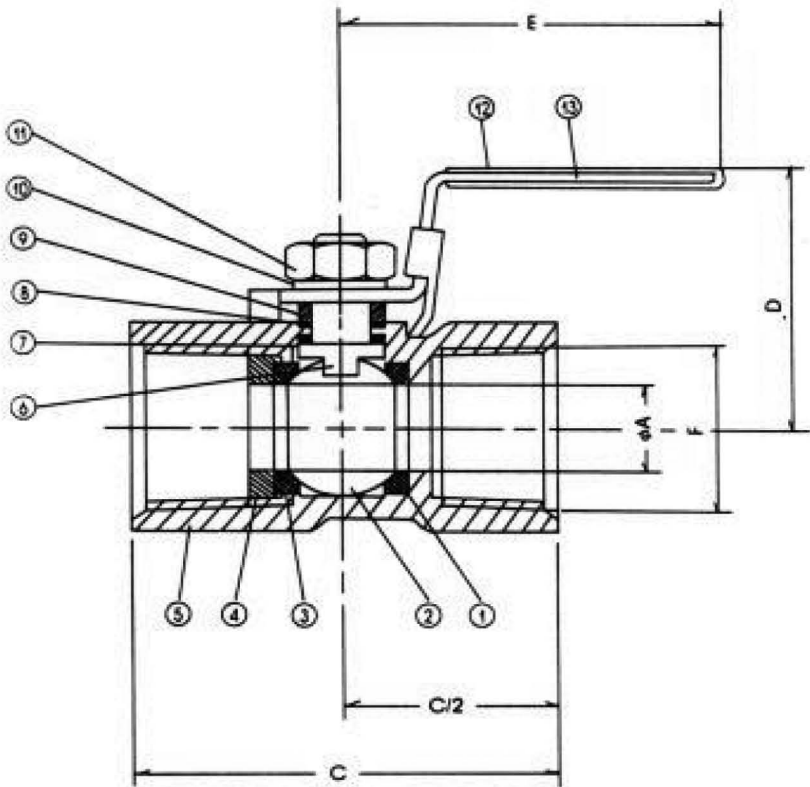

AK-8412
1-PC TYPE BALL VALVE
 REDUCED BORE, 1000 WOG
 SCREWED ENDS,
 INVESTMENT CASTING.

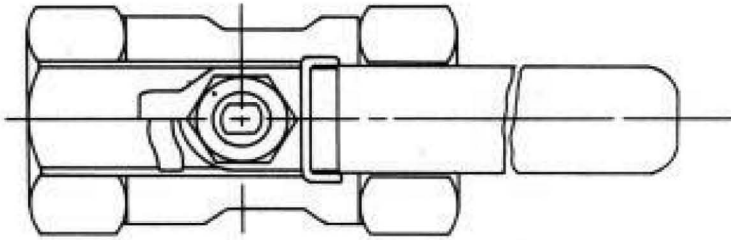

: MATERIALS LIST :

NO.	PART NAME	Q'TY	MATERIAL
1	SEAT	2	PTFE
2	BALL	1	ASTM A351 GR CF8M
3	JOINT GASKET	1	TEFLON
4	CAP	1	SS 316
5	BODY	1	ASTM A351 GR CF8M
6	STEM	1	SS 316
7	THRUST WASHER	1	PTFE
8	STEM PACKING	1	TEFLON
9	GLAND NUT	1	SS 304
10	STEM WASHER	1	SS 304
11	STEM NUT	1	SS 304
12	PLASTIC COVER	1	PLASTIC
13	HANDLE	1	SS 304

: DIMENSIONAL LIST :

SIZE	A	C	D	E	F
1/4"	5.0	39	35	64	1/4" PF-NPT-PT
3/8"	7.0	44	37	70	3/8" PF-NPT-PT
1/2"	9.2	56.5	43.5	90	1/2" PF-NPT-PT
3/4"	12.5	58	47	90	3/4" PF-NPT-PT
1"	15.0	71	50	103	1" PF-NPT-PT
1-1/4"	20.0	78	57	103	1-1/4" PF-NPT-PT
1-1/2"	24.5	83	69	127	1-1/2" PF-NPT-PT
2"	32.0	100	74.5	127	2" PF-NPT-PT