

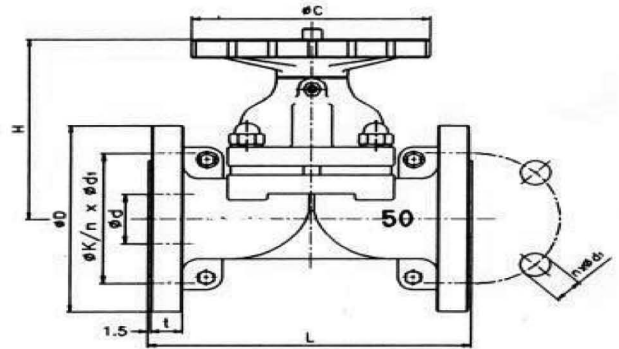

**AK-8114C  
DIAPHRAGM VALVE  
(PORCELAIN & NEOPRENE)  
MATERIAL: CAST IRON  
SIZE: 1/2" THRU 10"**

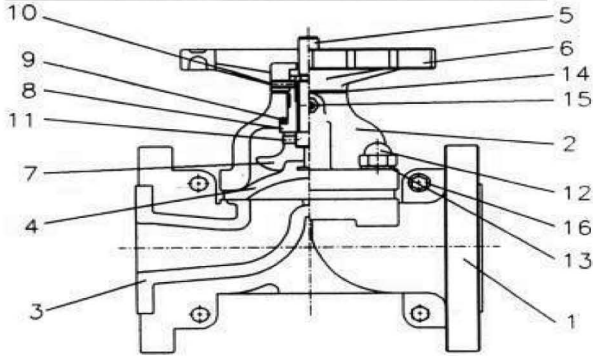

Valve body material : FC 20  
Lined material : Ceramic/NEOPERENE  
Diaphragm material : PTFE with rubber pad

**End connection**

JIS 10K  
ANSI 150LB  
DIN PN16

ITEM	DESCRIPTION	Q'TY	MAIERIAL
1	Valve body	1	FC 20
2	Bonnet	1	FC 20
3	Lining	1	Ceramic
4	Diaphragm	1	PTFE with rubber pad
5	Stem	1	SS41/SUS304SS
6	Hand wheel	1	FCD 40
7	Compressor	1	FC 20
8	Stem bush	1	Bronze
9	Trust bearing	1	Bronze
10	Fitting screw	1	Carbon steel
11	Set pin	1	SUS304SS
12	Bolts & Nuts	4	SS41(Znic-plating)
13	Spring washer	4	Spring stee(Znic plating)
14	Washer	1	PTFE
15	Grese nipple	1	Bronze
16	Nut	4	SS41

SIZE	L1	H	ΦC	t	JIS 10K			ANSI 150LB			DIN PN16		
					ΦD	ΦK	nxΦd1	ΦD	ΦK	nxΦd1	ΦD	ΦK	nxΦd1
15	135	97	105	16	95	70	4x15	89	60.5	4x16	95	65	4x14
20	135	102	105	18	100	75	4x15	98	70.0	4x16	105	75	4x14
25	145	117	105	18	125	90	4x19	108	79.5	4x16	115	85	4x15
40	180	152	135	20	140	105	4x19	127	98.5	4x16	150	110	4x18
50	210	157	155	20	155	120	4x19	152	120.5	4x19	165	125	4x18
65	250	182	180	22	175	140	4x19	178	139.5	4x19	185	145	4x18
80	300	192	210	22	185	150	8x19	190	152.5	4x19	200	160	8x18
100	350	232	230	24	210	175	8x22	254	216.0	8x22	250	210	8x18
125	400	302	280	24	250	210	8x22	254	216.0	8x22	250	210	8x18
150	460	352	320	25	280	240	8x22	279	241.5	8x22	285	240	8x23