

AK-8131
3-PC TYPE BALL VALVES ,FLANGED ENDS
 FLANGED ANSI 150LB., DIN PN16/40-F1
 MATERIAL: S.S. 316 AND C.S. WCB
 FULL PORT, INVESTMENT CASTING,
 SIZE: 1/2" THRU 4"

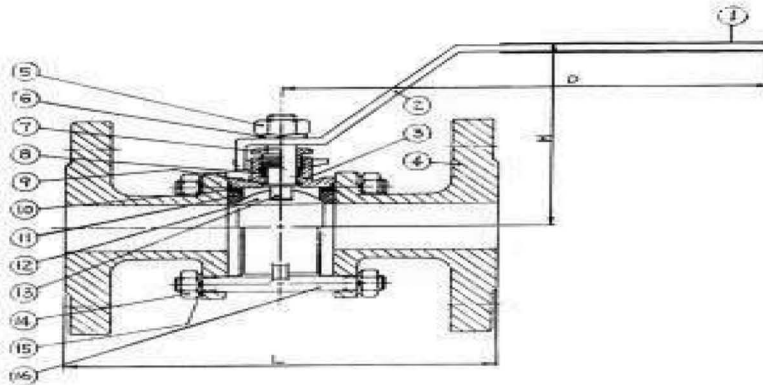
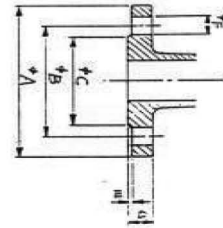

PN16

Unit : mm

PN 40

SINE DN	ψA	ψB	ψC	D	E	ψF	Bolt	
							Number	Plam.
15	95	65	45	14	2	14	4	M12
20	105	75	58	16	2	14	4	M12
25	115	85	68	16	2	14	4	M12
32	140	100	78	16	2	18	4	M16
40	150	110	88	16	3	18	4	M16
50	165	125	102	18	3	18	4	M16
65	185	145	122	18	3	18	4	M16
80	200	160	138	20	3	18	8	M16
100	220	180	158	20	3	18	8	M16

SINE DN	ψA	ψB	ψC	D	E	ψF	Bolt	
							Number	Plam.
15	95	65	45	14	2	14	4	M12
20	105	75	58	16	2	14	4	M12
25	115	85	68	16	2	14	4	M12
32	140	100	78	16	2	18	4	M16
40	150	110	88	16	3	18	4	M16
50	165	125	102	18	3	18	4	M16
65	185	145	122	18	3	18	8	M16
80	200	160	138	20	3	18	8	M16
100	235	190	162	24	3	22	8	M20

: MATERIAL LIST :

NO.	PARTS NAME	MATERIAL	Q'TY
1	PLASTIC COVER	PVC	1
2	HANDLE	SUS 304	1
3	BODY	316//304	1
4	CAP	316 /304	2
5	STEM NUT	SUS 304	1
6	SPRING WASHER	SUS 304	1
7	GLAND NUT	SUS 304	1
8	STEM PACKING	PTFE	1S
9	THRUST WASHER	PTFE	1
10	PACKING	PTFE	2
11	BALL SEAT	15% G.F	2
12	BALL	316/304	1
13	STEM	SUS 316	1
14	BOLT NUT	SUS 304	8:12
15	BOLT WASHER	SUS 304	8:12
16	BOLT	SUS 304	4:6

ANSI 150LB

SIZE		A	L	H	D
mm	inch	mm	mm	mm	mm
15	1/2	16	108	74.5	110
20	3/4	20	117	79.0	125
25	1	24.5	127	84.0	145
32	1 1/4	32	140	89.6	145
40	1 1/2	38	165	96.7	175
50	2	50	178	106	175

PN16 & PN40-F1

SIZE	15	20	25	32	40	50	65	80	100
	1/2"	3/4"	1"	1-1/4"	1-1/2"	2"	2-1/2"	3"	4"
L	130	150	160	180	200	230	290	310	350
H	152	152	176	176	207	207	285	285	291
D	87	91	99	104	127	136	167	176	173