

AK-8243
3-WAY TYPE BALL VALVES, SCREWED ENDS
 MATERIAL: S.S.316
 STANDARD PORT,
 INVESTMENT CASTING (360 DEGREE)
 SIZE: 1/4" THRU 2"

:TEST PRESSURE:
 1.WORKING PRESSURE: 56.30 KG/CM2
 2.BALL SEAT TEST: 6.0 KG/CM2 BY AIR
 3.BODY TEST: 84.50 KG/CM2 BY HYDROSTATIC

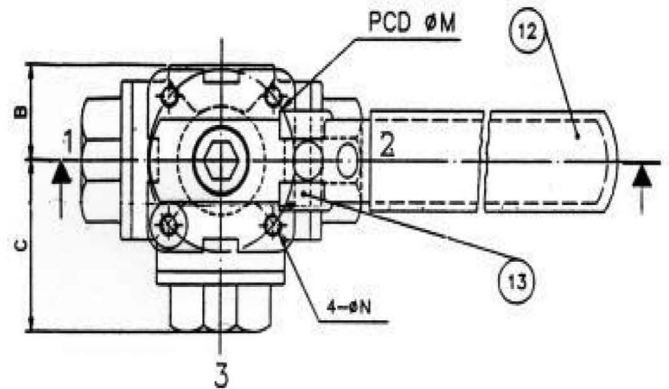

· MATERIALS LIST :

NO.	PART NAME	Q' TY	MATERIAL
1	BODY	1	SS-316
2	CAP	3	SS-316
3	STEM	1	SS-316
4	GLAND NUT	1	SS-304
5	BALL	1	SS-316
6	SEAT	4	REINFORCED PTFE
7	THRUST WASHER	1	PTFE
8	PACKING	1-2	PTFE
9	GASKET	3	PTFE
10	STEM BOLT	1	SS-304
11	WASHER	1	SS-304
12	HADLE	1	SS-304
13	PLASTIC COVER	1	PLASTIC

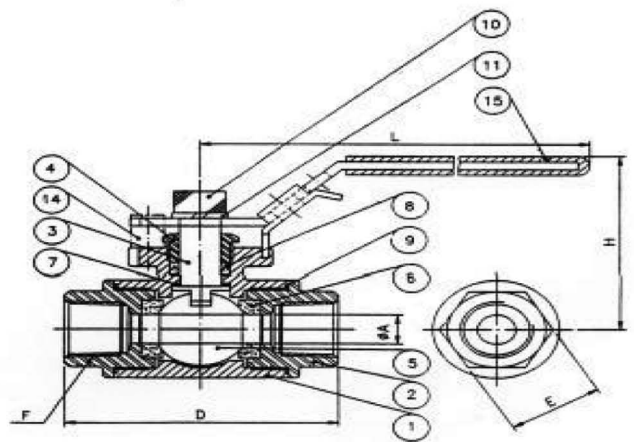

POSITION	A	B	C	D
L PORT				
T PORT				

· DIMENSIONAL LIST :

SIZE	A	B	C	D	E	H	L	M	N	F
TOL										NPT/ISO228 PT/DIN2999
1/4"	9.5	22	39.5	79	28.5	64.5	160	42	M5x0.8	↓
3/8"	9.5	22	39.5	79	28.5	64.5	160	42	M5x0.8	↓
1/2"	12	22	39.5	79	28.5	64.5	160	42	M5x0.8	↓
3/4"	15	28	44	88	34.5	77.5	190	50	M6x1.0	↓
1"	20	31	54	108	41	81	190	50	M6x1.0	↓
1-1/4"	25	34	62	124	52	88	200	50	M6x1.0	↓
1-1/2"	32	40	67.5	135	58	93	250	70	M8x1.25	↓
2"	40	48	82	164	73	105	250	70	M8x1.25	↓